

### FEATURES

**Bidirectional level translation**  
**Operates from 1.15 V to 5.5 V**  
**Low quiescent current < 5  $\mu$ A**  
**No direction pin**

### APPLICATIONS

**SPI<sup>®</sup>, MICROWIRE<sup>™</sup> level translation**  
**Low voltage ASIC level translation**  
**Smart card readers**  
**Cell phones and cell phone cradles**  
**Portable communications devices**  
**Telecommunications equipment**  
**Network switches and routers**  
**Storage systems (SAN/NAS)**  
**Computing/server applications**  
**GPS**  
**Portable POS systems**  
**Low cost serial interfaces**

### GENERAL DESCRIPTION

The ADG3304 is a bidirectional logic level translator that contains four bidirectional channels. It can be used in multivoltage digital system applications such as data transfer between a low voltage DSP/controller and a higher voltage device using SPI and MICROWIRE interfaces. The internal architecture allows the device to perform bidirectional logic level translation without an additional signal to set the direction in which the translation takes place.

The voltage applied to  $V_{CCA}$  sets the logic levels on the A side of the device, while  $V_{CCY}$  sets the levels on the Y side. For proper operation,  $V_{CCA}$  must always be less than  $V_{CCY}$ . The  $V_{CCA}$ -compatible logic signals applied to the A side of the device appear as  $V_{CCY}$ -compatible levels on the Y side. Similarly,  $V_{CCY}$ -compatible logic levels applied to the Y side of the device appear as  $V_{CCA}$ -compatible logic levels on the A side.

#### Rev. A

Information furnished by Analog Devices is believed to be accurate and reliable. However, no responsibility is assumed by Analog Devices for its use, nor for any infringements of patents or other rights of third parties that may result from its use. Specifications subject to change without notice. No license is granted by implication or otherwise under any patent or patent rights of Analog Devices. Trademarks and registered trademarks are the property of their respective owners.

### FUNCTIONAL BLOCK DIAGRAM

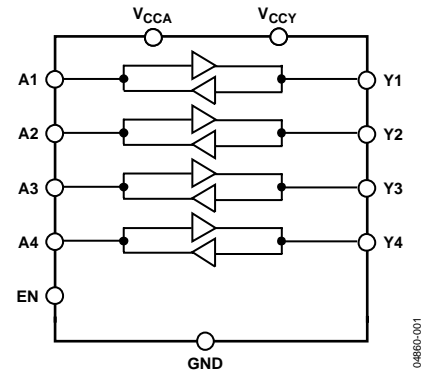

Figure 1.

The enable pin (EN) provides three-state operation on both the A-side and the Y-side pins. When the EN pin is pulled low, the terminals on both sides of the device are in the high impedance state. The EN pin is referred to the  $V_{CCA}$  supply voltage and driven high for normal operation.

The ADG3304 is available in compact 14-lead TSSOP, 12-bump WLCSP, and 20-lead LFCSP packages. It is guaranteed to operate over the 1.15 V to 5.5 V supply voltage range and the extended  $-40^{\circ}\text{C}$  to  $+85^{\circ}\text{C}$  temperature range.

### PRODUCT HIGHLIGHTS

1. Bidirectional level translation.
2. Fully guaranteed over the 1.15 V to 5.5 V supply range.
3. No direction pin.
4. Available in 14-lead TSSOP, 12-bump WLCSP, and 20-lead LFCSP packages.

# TABLE OF CONTENTS

Specifications.....	3	Input Driving Requirements.....	16
Absolute Maximum Ratings.....	6	Output Load Requirements .....	16
ESD Caution.....	6	Enable Operation .....	16
Pin Configurations and Function Descriptions .....	7	Power Supplies.....	16
Typical Performance Characteristics .....	8	Data Rate .....	17
Test Circuits.....	12	Applications.....	18
Terminology .....	15	Layout Guidelines.....	18
Theory of Operation .....	16	Outline Dimensions .....	19
Level Translator Architecture .....	16	Ordering Guide .....	19

## REVISION HISTORY

**6/05—Rev. 0 to Rev. A**  
Added LFCSP Package..... Universal

**1/05—Revision 0: Initial Version**

## SPECIFICATIONS<sup>1</sup>

$V_{CCY} = 1.65\text{ V to }5.5\text{ V}$ ,  $V_{CCA} = 1.15\text{ V to }V_{CCY}$ ,  $GND = 0\text{ V}$ . All specifications  $T_{MIN}$  to  $T_{MAX}$ , unless otherwise noted.

**Table 1.**

Parameter	Symbol	Conditions	Min	Typ <sup>2</sup>	Max	Unit
<b>LOGIC INPUTS/OUTPUTS</b>						
<b>A Side</b>						
Input High Voltage <sup>3</sup>	$V_{IHA}$	$V_{CCA} = 1.15\text{ V}$	$V_{CCA} - 0.3$			V
	$V_{IHA}$	$V_{CCA} = 1.2\text{ V to }5.5\text{ V}$	$V_{CCA} - 0.4$			V
Input Low Voltage <sup>3</sup>	$V_{ILA}$				0.4	V
Output High Voltage	$V_{OHA}$	$V_Y = V_{CCY}$ , $I_{OH} = 20\text{ }\mu\text{A}$ , Figure 29	$V_{CCA} - 0.4$			V
Output Low Voltage	$V_{OLA}$	$V_Y = 0\text{ V}$ , $I_{OL} = 20\text{ }\mu\text{A}$ , Figure 29			0.4	V
Capacitance <sup>3</sup>	$C_A$	$f = 1\text{ MHz}$ , $EN = 0$ , Figure 34		9		pF
Leakage Current	$I_{LA, HI-Z}$	$V_A = 0\text{ V}/V_{CCA}$ , $EN = 0$ , Figure 31			$\pm 1$	$\mu\text{A}$
<b>Y Side</b>						
Input Low Voltage <sup>3</sup>	$V_{IHY}$		$V_{CCY} - 0.4$			V
Input High Voltage <sup>3</sup>	$V_{ILY}$				0.4	V
Output High Voltage	$V_{OHY}$	$V_A = V_{CCA}$ , $I_{OH} = 20\text{ }\mu\text{A}$ , Figure 30	$V_{CCY} - 0.4$			V
Output Low Voltage	$V_{OLY}$	$V_A = 0\text{ V}$ , $I_{OL} = 20\text{ }\mu\text{A}$ , Figure 30			0.4	V
Capacitance <sup>3</sup>	$C_Y$	$f = 1\text{ MHz}$ , $EN = 0$ , Figure 35		6		pF
Leakage Current	$I_{LY, HI-Z}$	$V_Y = 0\text{ V}/V_{CCY}$ , $EN = 0$ , Figure 32			$\pm 1$	$\mu\text{A}$
<b>Enable (EN)</b>						
Input High Voltage <sup>3</sup>	$V_{IHEN}$	$V_{CCA} = 1.15\text{ V}$	$V_{CCA} - 0.3$			V
	$V_{IHEN}$	$V_{CCA} = 1.2\text{ V to }5.5\text{ V}$	$V_{CCA} - 0.4$			V
Input Low Voltage <sup>3</sup>	$V_{ILEN}$				0.4	V
Leakage Current	$I_{LEN}$	$V_{EN} = 0\text{ V}/V_{CCA}$ , $V_A = 0\text{ V}$ , Figure 33			$\pm 1$	$\mu\text{A}$
Capacitance <sup>3</sup>	$C_{EN}$			3		pF
Enable Time <sup>3</sup>	$t_{EN}$	$R_S = R_T = 50\text{ }\Omega$ , $V_A = 0\text{ V}/V_{CCA}$ (A $\rightarrow$ Y), $V_Y = 0\text{ V}/V_{CCY}$ (Y $\rightarrow$ A), Figure 36		1	1.8	$\mu\text{s}$
<b>SWITCHING CHARACTERISTICS<sup>3</sup></b>						
$3.3\text{ V} \pm 0.3\text{ V} \leq V_{CCA} \leq V_{CCY}$ , $V_{CCY} = 5\text{ V} \pm 0.5\text{ V}$						
<b>A<math>\rightarrow</math>Y Level Translation</b>						
Propagation Delay	$t_{P, A\rightarrow Y}$	$R_S = R_T = 50\text{ }\Omega$ , $C_L = 50\text{ pF}$ , Figure 37		6	10	ns
Rise Time	$t_{R, A\rightarrow Y}$			2	3.5	ns
Fall Time	$t_{F, A\rightarrow Y}$			2	3.5	ns
Maximum Data Rate	$D_{MAX, A\rightarrow Y}$		50			Mbps
Channel-to-Channel Skew	$t_{SKEW, A\rightarrow Y}$			2	4	ns
Part-to-Part Skew	$t_{PPSKEW, A\rightarrow Y}$				3	ns
<b>Y<math>\rightarrow</math>A Level Translation</b>						
Propagation Delay	$t_{P, Y\rightarrow A}$	$R_S = R_T = 50\text{ }\Omega$ , $C_L = 15\text{ pF}$ , Figure 38		4	7	ns
Rise Time	$t_{R, Y\rightarrow A}$			1	3	ns
Fall Time	$t_{F, Y\rightarrow A}$			3	7	ns
Maximum Data Rate	$D_{MAX, Y\rightarrow A}$		50			Mbps
Channel-to-Channel Skew	$t_{SKEW, Y\rightarrow A}$			2	3.5	ns
Part-to-Part Skew	$t_{PPSKEW, Y\rightarrow A}$				2	ns
$1.8\text{ V} \pm 0.15\text{ V} \leq V_{CCA} \leq V_{CCY}$ , $V_{CCY} = 3.3\text{ V} \pm 0.3\text{ V}$						
<b>A<math>\rightarrow</math>Y Translation</b>						
Propagation Delay	$t_{P, A\rightarrow Y}$	$R_S = R_T = 50\text{ }\Omega$ , $C_L = 50\text{ pF}$ , Figure 37		8	11	ns
Rise Time	$t_{R, A\rightarrow Y}$			2	5	ns
Fall Time	$t_{F, A\rightarrow Y}$			2	5	ns
Maximum Data Rate	$D_{MAX, A\rightarrow Y}$		50			Mbps

# ADG3304

Parameter	Symbol	Conditions	Min	Typ <sup>2</sup>	Max	Unit
Channel-to-Channel Skew	t <sub>SKEW, A→Y</sub>			2	4	ns
Part-to-Part Skew	t <sub>PPSKEW, A→Y</sub>				4	ns
Y→A Translation		R <sub>S</sub> = R <sub>T</sub> = 50 Ω, C <sub>L</sub> = 15 pF, Figure 38				
Propagation Delay	t <sub>P, Y→A</sub>			5	8	ns
Rise Time	t <sub>R, Y→A</sub>			2	3.5	ns
Fall Time	t <sub>F, Y→A</sub>			2	3.5	ns
Maximum Data Rate	D <sub>MAX, Y→A</sub>		50			Mbps
Channel-to-Channel Skew	t <sub>SKEW, Y→A</sub>			2	3	ns
Part-to-Part Skew	t <sub>PPSKEW, Y→A</sub>				3	ns
1.15 V to 1.3 V ≤ V <sub>CCA</sub> ≤ V <sub>CCY</sub> , V <sub>CCY</sub> = 3.3 V ± 0.3 V						
A→Y Translation		R <sub>S</sub> = R <sub>T</sub> = 50 Ω, C <sub>L</sub> = 50 pF, Figure 37				
Propagation Delay	t <sub>P, A→Y</sub>			9	18	ns
Rise Time	t <sub>R, A→Y</sub>			3	5	ns
Fall Time	t <sub>F, A→Y</sub>			2	5	ns
Maximum Data Rate	D <sub>MAX, A→Y</sub>		40			Mbps
Channel-to-Channel Skew	t <sub>SKEW, A→Y</sub>			2	5	ns
Part-to-Part Skew	t <sub>PPSKEW, A→Y</sub>				10	ns
Y→A Translation		R <sub>S</sub> = R <sub>T</sub> = 50 Ω, C <sub>L</sub> = 15 pF, Figure 38				
Propagation Delay	t <sub>P, Y→A</sub>			5	9	ns
Rise Time	t <sub>R, Y→A</sub>			2	4	ns
Fall Time	t <sub>F, Y→A</sub>			2	4	ns
Maximum Data Rate	D <sub>MAX, Y→A</sub>		40			Mbps
Channel-to-Channel Skew	t <sub>SKEW, Y→A</sub>			2	4	ns
Part-to-Part Skew	t <sub>PPSKEW, Y→A</sub>				4	ns
1.15 V to 1.3 V ≤ V <sub>CCA</sub> ≤ V <sub>CCY</sub> , V <sub>CCY</sub> = 1.8 V ± 0.3 V						
A→Y Translation		R <sub>S</sub> = R <sub>T</sub> = 50 Ω, C <sub>L</sub> = 50 pF, Figure 37				
Propagation Delay	t <sub>P, A→Y</sub>			12	25	ns
Rise Time	t <sub>R, A→Y</sub>			7	12	ns
Fall Time	t <sub>F, A→Y</sub>			3	5	ns
Maximum Data Rate	D <sub>MAX, A→Y</sub>		25			Mbps
Channel-to-Channel Skew	t <sub>SKEW, A→Y</sub>			2	5	ns
Part-to-Part Skew	t <sub>PPSKEW, A→Y</sub>				15	ns
Y→A Translation		R <sub>S</sub> = R <sub>T</sub> = 50 Ω, C <sub>L</sub> = 15 pF, Figure 38				
Propagation Delay	t <sub>P, Y→A</sub>			14	35	ns
Rise Time	t <sub>R, Y→A</sub>			5	16	ns
Fall Time	t <sub>F, Y→A</sub>			2.5	6.5	ns
Maximum Data Rate	D <sub>MAX, Y→A</sub>		25			Mbps
Channel-to-Channel Skew	t <sub>SKEW, Y→A</sub>			3	6.5	ns
Part-to-Part Skew	t <sub>PPSKEW, Y→A</sub>				23.5	ns
2.5 V ± 0.2 V ≤ V <sub>CCA</sub> ≤ V <sub>CCY</sub> , V <sub>CCY</sub> = 3.3 V ± 0.3 V						
A→Y Translation		R <sub>S</sub> = R <sub>T</sub> = 50 Ω, C <sub>L</sub> = 50 pF, Figure 37				
Propagation Delay	t <sub>P, A→Y</sub>			7	10	ns
Rise Time	t <sub>R, A→Y</sub>			2.5	4	ns
Fall Time	t <sub>F, A→Y</sub>			2	5	ns
Maximum Data Rate	D <sub>MAX, A→Y</sub>		60			Mbps
Channel-to-Channel Skew	t <sub>SKEW, A→Y</sub>			1.5	2	ns
Part-to-Part Skew	t <sub>PPSKEW, A→Y</sub>				4	ns

Parameter	Symbol	Conditions	Min	Typ <sup>2</sup>	Max	Unit
Y→A Translation		$R_S = R_T = 50 \Omega$ , $C_L = 15 \text{ pF}$ , Figure 38				
Propagation Delay	$t_{P, Y \rightarrow A}$			5	8	ns
Rise Time	$t_{R, Y \rightarrow A}$			1	4	ns
Fall Time	$t_{F, Y \rightarrow A}$			3	5	ns
Maximum Data Rate	$D_{MAX, Y \rightarrow A}$		60			Mbps
Channel-to-Channel Skew	$t_{SKEW, Y \rightarrow A}$			2	3	ns
Part-to-Part Skew	$t_{PPSKEW, Y \rightarrow A}$				3	ns
<b>POWER REQUIREMENTS</b>						
Power Supply Voltages	$V_{CCA}$ $V_{CCY}$	$V_{CCA} \leq V_{CCY}$	1.15 1.65		5.5 5.5	V V
Quiescent Power Supply Current	$I_{CCA}$ $I_{CCY}$	$V_A = 0 \text{ V}/V_{CCA}$ , $V_Y = 0 \text{ V}/V_{CCY}$ , $V_{CCA} = V_{CCY} = 5.5 \text{ V}$ , $EN = 1$ $V_A = 0 \text{ V}/V_{CCA}$ , $V_Y = 0 \text{ V}/V_{CCY}$ , $V_{CCA} = V_{CCY} = 5.5 \text{ V}$ , $EN = 1$		0.17 0.27	5 5	$\mu\text{A}$ $\mu\text{A}$
Three-State Mode Power Supply Current	$I_{HI-Z, A}$ $I_{HI-Z, Y}$	$V_{CCA} = V_{CCY} = 5.5 \text{ V}$ , $EN = 0$ $V_{CCA} = V_{CCY} = 5.5 \text{ V}$ , $EN = 0$		0.1 0.1	5 5	$\mu\text{A}$ $\mu\text{A}$

<sup>1</sup> Temperature range is as follows: B version:  $-40^\circ\text{C}$  to  $+85^\circ\text{C}$ .

<sup>2</sup> All typical values are at  $T_A = 25^\circ\text{C}$ , unless otherwise noted.

<sup>3</sup> Guaranteed by design; not subject to production test.

## ABSOLUTE MAXIMUM RATINGS

T<sub>A</sub> = 25°C, unless otherwise noted.

**Table 2.**

Parameter	Rating
V <sub>CCA</sub> to GND	−0.3 V to +7 V
V <sub>CCY</sub> to GND	V <sub>CCA</sub> to +7 V
Digital Inputs (A)	−0.3 V to (V <sub>CCA</sub> + 0.3 V)
Digital Inputs (Y)	−0.3 V to (V <sub>CCY</sub> + 0.3 V)
EN to GND	−0.3 V to +7 V
Operating Temperature Range	
Industrial (B Version)	−40°C to +85°C
Storage Temperature Range	−65°C to +150°C
Junction Temperature	150°C
θ <sub>JA</sub> Thermal Impedance (4-Layer Board)	
14-Lead TSSOP	89.21°C/W
12-Bump WLCSP	120°C/W
20-Lead LFCSP	30.4°C/W
Lead Temperature, Soldering (10 sec)	300°C
IR Reflow, Peak Temperature (<20 sec)	260°C

Stresses above those listed under Absolute Maximum Ratings may cause permanent damage to the device. This is a stress rating only; functional operation of the device at these or any other conditions above those listed in the operational sections of this specification is not implied. Exposure to absolute maximum rating conditions for extended periods may affect device reliability. Only one absolute maximum rating may be applied at any one time.

### ESD CAUTION

ESD (electrostatic discharge) sensitive device. Electrostatic charges as high as 4000 V readily accumulate on the human body and test equipment and can discharge without detection. Although this product features proprietary ESD protection circuitry, permanent damage may occur on devices subjected to high energy electrostatic discharges. Therefore, proper ESD precautions are recommended to avoid performance degradation or loss of functionality.



# PIN CONFIGURATIONS AND FUNCTION DESCRIPTIONS

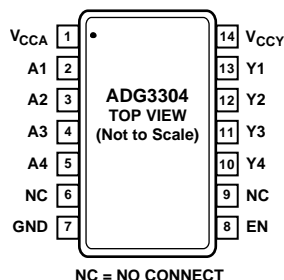

Figure 2. 14-Lead TSSOP

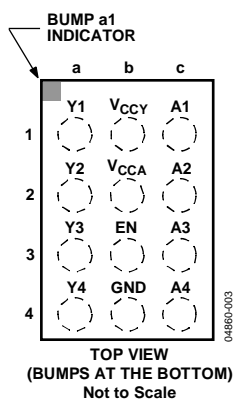
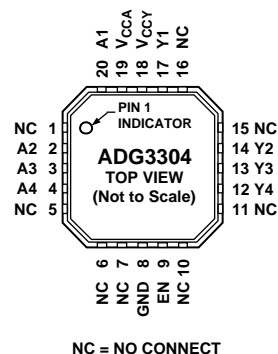

Figure 3. 12-Bump WLCSP



NOTES  
1. THE EXPOSED PADDLE CAN BE TIED TO GND OR LEFT FLOATING. DO NOT TIE IT TO V<sub>CCA</sub> or V<sub>CCY</sub>.

Figure 4. 20-Lead LFCSP

Table 3. 14-Lead TSSOP and 20-lead LFCSP Pin Function Descriptions

Pin No.		Mnemonic	Description
TSSOP	LFCSP		
1	19	V <sub>CCA</sub>	Power Supply Voltage Input for the A1 to A4 I/O Pins ( $1.15\text{ V} \leq V_{CCA} \leq V_{CCY}$ ).
2	20	A1	Input/Output A1. Referenced to V <sub>CCA</sub> .
3	2	A2	Input/Output A2. Referenced to V <sub>CCA</sub> .
4	3	A3	Input/Output A3. Referenced to V <sub>CCA</sub> .
5	4	A4	Input/Output A4. Referenced to V <sub>CCA</sub> .
6, 9	1, 5, 6, 7, 10, 11, 15, 16	NC	No Connect.
7	8	GND	Ground.
8	9	EN	Active High Enable Input.
10	12	Y4	Input/Output Y4. Referenced to V <sub>CCY</sub> .
11	13	Y3	Input/Output Y3. Referenced to V <sub>CCY</sub> .
12	14	Y2	Input/Output Y2. Referenced to V <sub>CCY</sub> .
13	17	Y1	Input/Output Y1. Referenced to V <sub>CCY</sub> .
14	18	V <sub>CCY</sub>	Power Supply Voltage Input for the Y1 to Y4 I/O Pins ( $1.65\text{ V} \leq V_{CC} \leq 5.5\text{ V}$ ).

Table 4. 12-Bump WLCSP Bump Function Descriptions

Bump No.	Mnemonic	Description
a1	Y1	Input/Output Y1. Referenced to V <sub>CCY</sub> .
a2	Y2	Input/Output Y2. Referenced to V <sub>CCY</sub> .
a3	Y3	Input/Output Y3. Referenced to V <sub>CCY</sub> .
a4	Y4	Input/Output Y4. Referenced to V <sub>CCY</sub> .
b1	V <sub>CCY</sub>	Power Supply Voltage Input for the Y1 to Y4 I/O Pins ( $1.65\text{ V} \leq V_{CC} \leq 5.5\text{ V}$ ).
b2	V <sub>CCA</sub>	Power Supply Voltage Input for the A1 to A4 I/O Pins ( $1.15\text{ V} \leq V_{CCA} \leq V_{CCY}$ ).
b3	EN	Active High Enable Input.
b4	GND	Ground.
c1	A1	Input/Output A1. Referenced to V <sub>CCA</sub> .
c2	A2	Input/Output A2. Referenced to V <sub>CCA</sub> .
c3	A3	Input/Output A3. Referenced to V <sub>CCA</sub> .
c4	A4	Input/Output A4. Referenced to V <sub>CCA</sub> .

TYPICAL PERFORMANCE CHARACTERISTICS

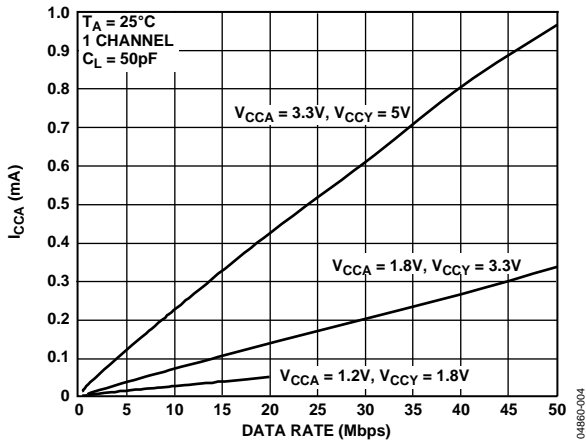

Figure 5.  $I_{CCA}$  vs. Data Rate (A→Y Level Translation)

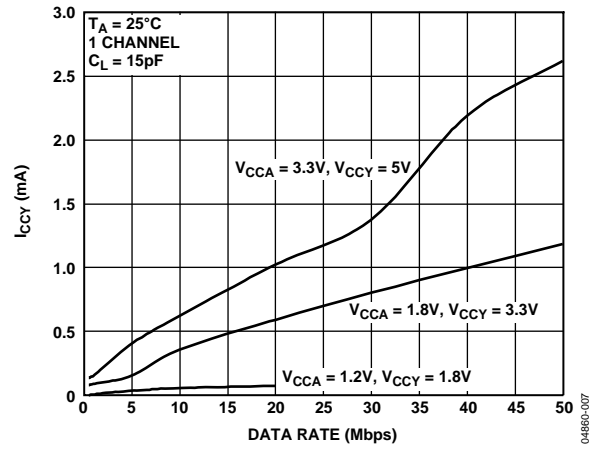

Figure 8.  $I_{CCY}$  vs. Data Rate (Y→A Level Translation)

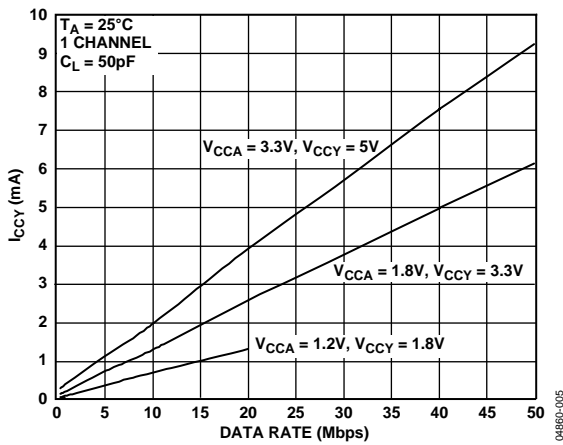

Figure 6.  $I_{CCY}$  vs. Data Rate (A→Y Level Translation)

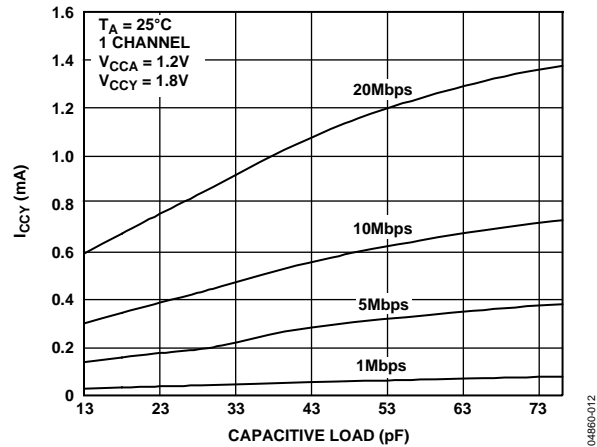

Figure 9.  $I_{CCY}$  vs. Capacitive Load at Pin Y for A→Y (1.2V→1.8V) Level Translation

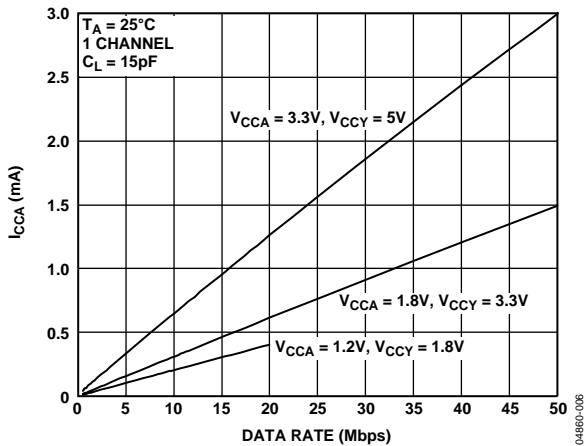

Figure 7.  $I_{CCA}$  vs. Data Rate (Y→A Level Translation)

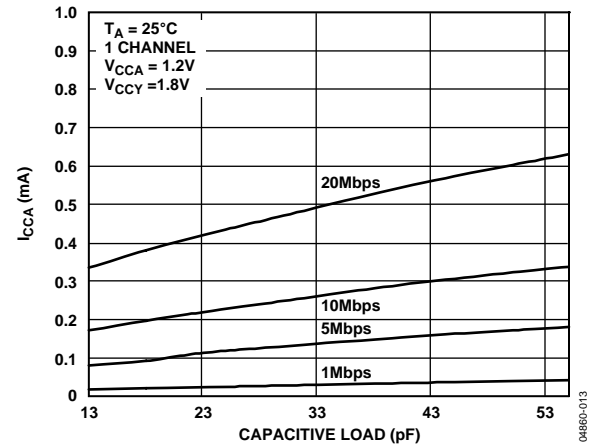

Figure 10.  $I_{CCA}$  vs. Capacitive Load at Pin A for Y→A (1.8V→1.2V) Level Translation



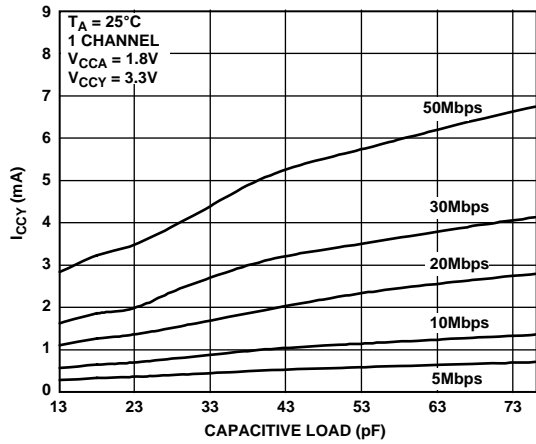

Figure 11.  $I_{CCY}$  vs. Capacitive Load at Pin Y for A $\rightarrow$ Y (1.8 V $\rightarrow$ 3.3 V) Level Translation

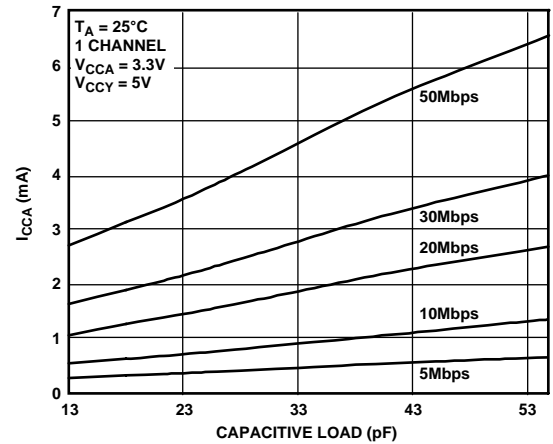

Figure 14.  $I_{CCA}$  vs. Capacitive Load at Pin A for Y $\rightarrow$ A (5 V $\rightarrow$ 3.3 V) Level Translation

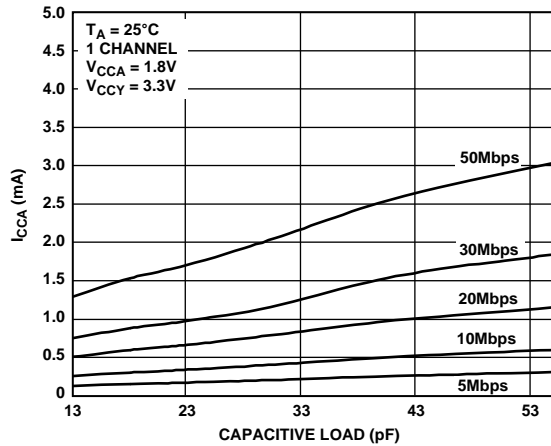

Figure 12.  $I_{CCA}$  vs. Capacitive Load at Pin A for Y $\rightarrow$ A (3.3 V $\rightarrow$ 1.8 V) Level Translation

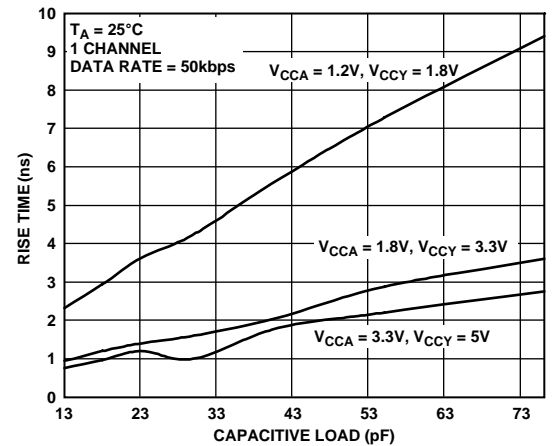

Figure 15. Rise Time vs. Capacitive Load at Pin Y (A $\rightarrow$ Y Level Translation)

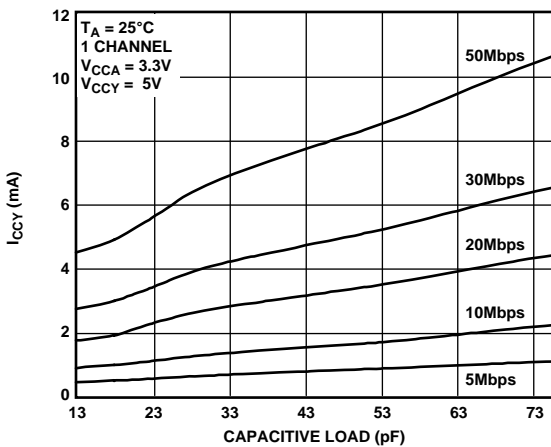

Figure 13.  $I_{CCY}$  vs. Capacitive Load at Pin Y for A $\rightarrow$ Y (3.3 V $\rightarrow$ 5 V) Level Translation

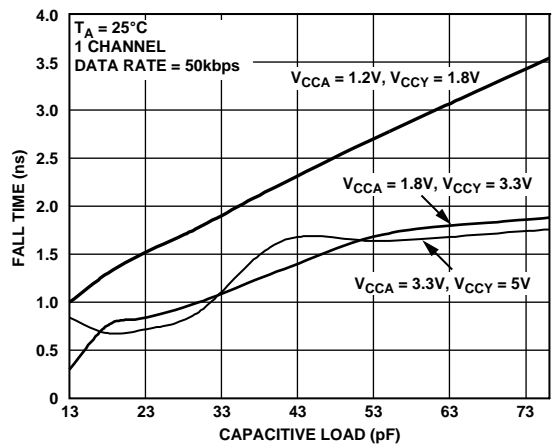

Figure 16. Fall Time vs. Capacitive Load at Pin Y (A $\rightarrow$ Y Level Translation)

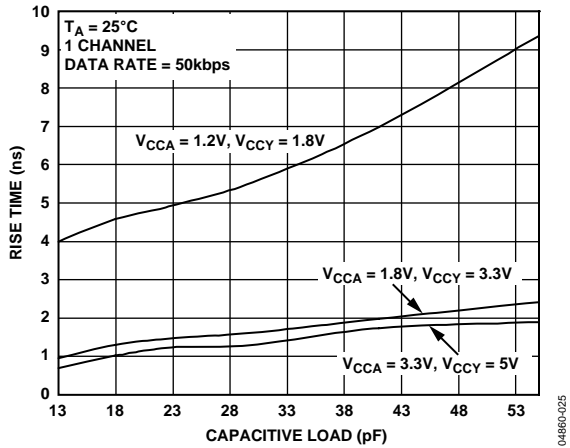

Figure 17. Rise Time vs. Capacitive Load at Pin A (Y→A Level Translation)

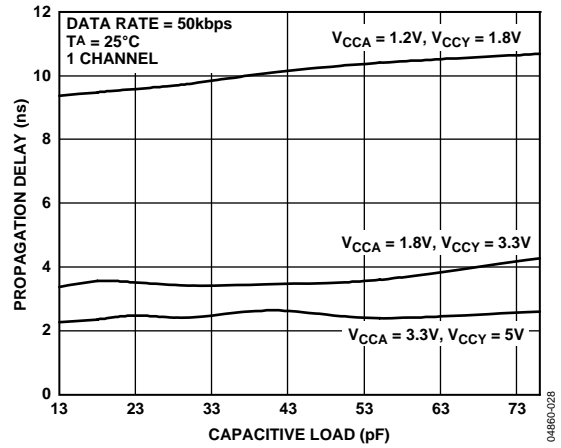

Figure 20. Propagation Delay ( $t_{PHL}$ ) vs. Capacitive Load at Pin Y (A→Y Level Translation)

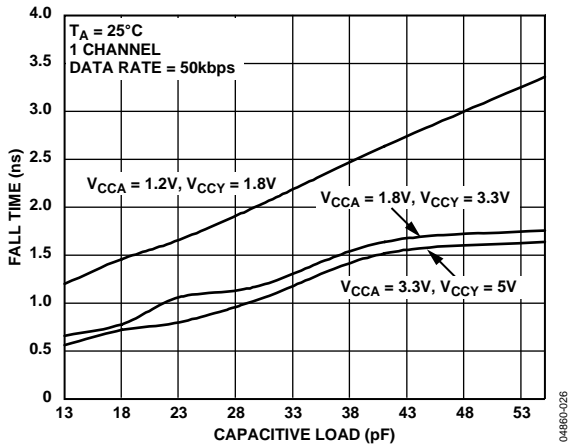

Figure 18. Fall Time vs. Capacitive Load at Pin A (Y→A Level Translation)

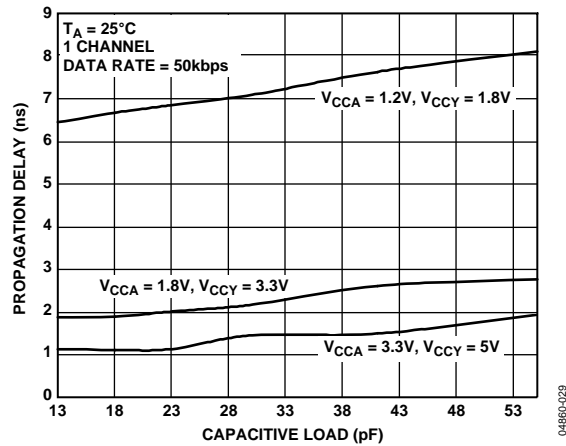

Figure 21. Propagation Delay ( $t_{PLH}$ ) vs. Capacitive Load at Pin A (Y→A Level Translation)

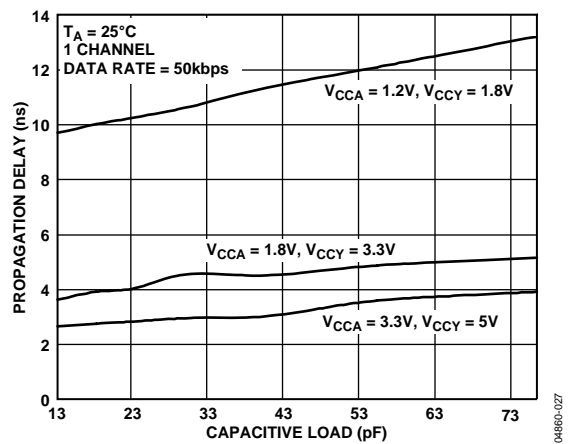

Figure 19. Propagation Delay ( $t_{PLH}$ ) vs. Capacitive Load at Pin Y (A→Y Level Translation)

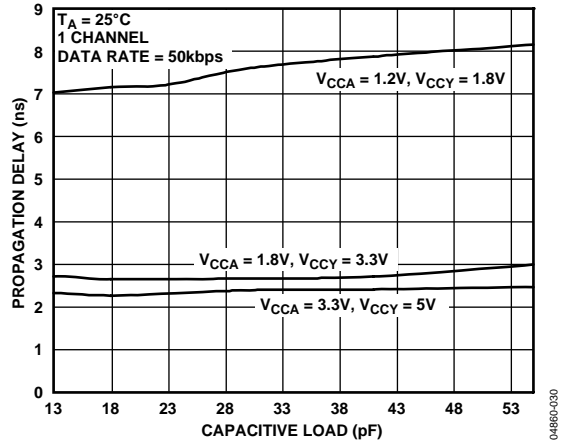

Figure 22. Propagation Delay ( $t_{PHL}$ ) vs. Capacitive Load at Pin A (Y→A Level Translation)

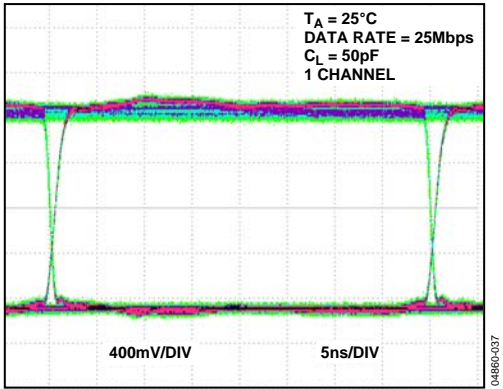

Figure 23. Eye Diagram at Y Output (1.2 V to 1.8 V Level Translation, 25 Mbps)

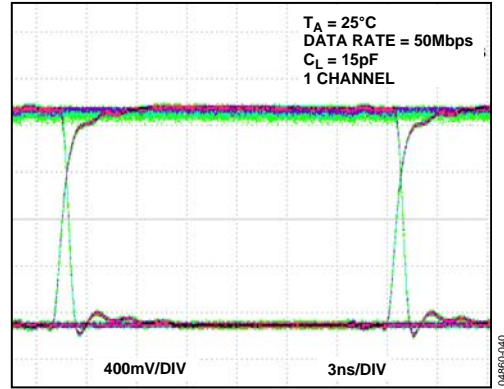

Figure 26. Eye Diagram at A Output (3.3 V to 1.8 V Level Translation, 50 Mbps)

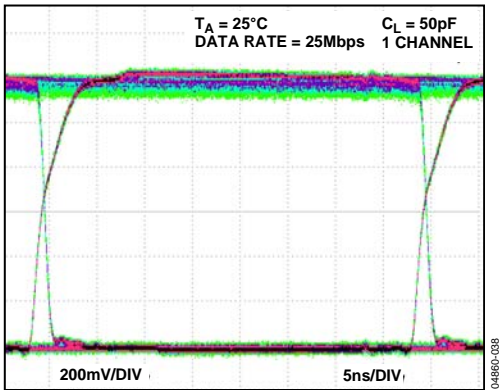

Figure 24. Eye Diagram at A Output (1.8 V to 1.2 V Level Translation, 25 Mbps)

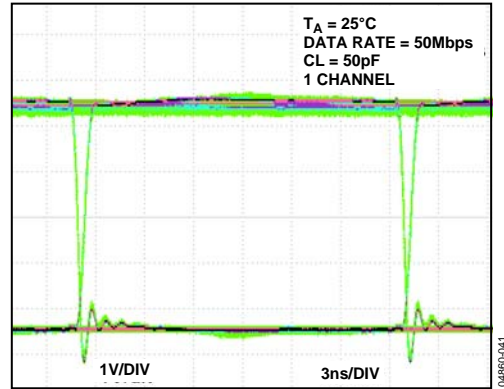

Figure 27. Eye Diagram at Y Output (3.3 V to 5 V Level Translation, 50 Mbps)

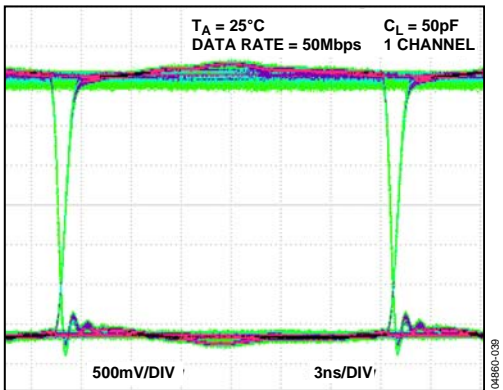

Figure 25. Eye Diagram at Y Output (1.8 V to 3.3 V Level Translation, 50 Mbps)

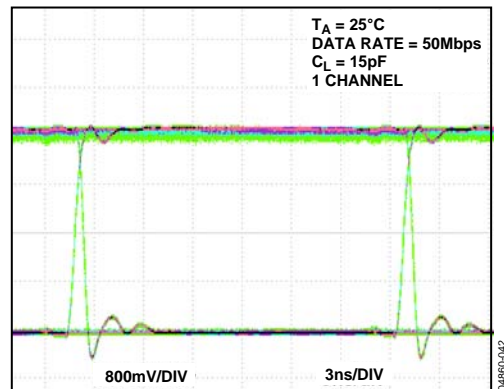

Figure 28. Eye Diagram at A Output (5 V to 3.3 V Level Translation, 50 Mbps)

# ADG3304

## TEST CIRCUITS

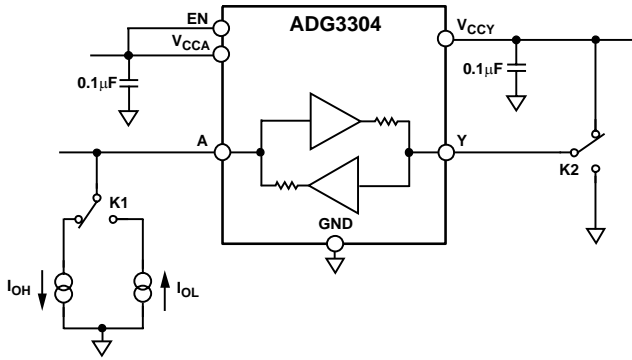

Figure 29.  $V_{OH}/V_{OL}$  Voltages at Pin A

04860-043

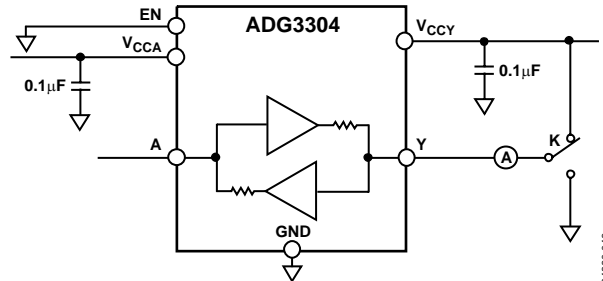

Figure 32. Three-State Leakage Current at Pin Y

04860-046

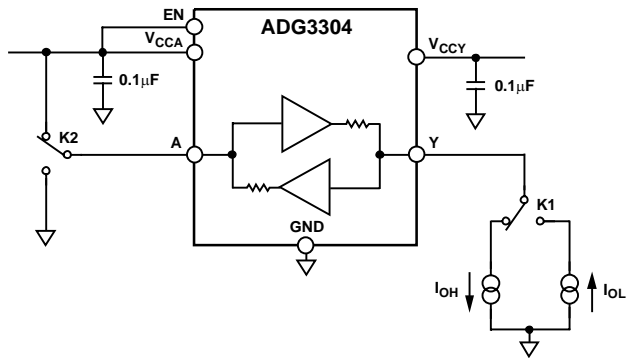

Figure 30.  $V_{OH}/V_{OL}$  Voltages at Pin Y

04860-044

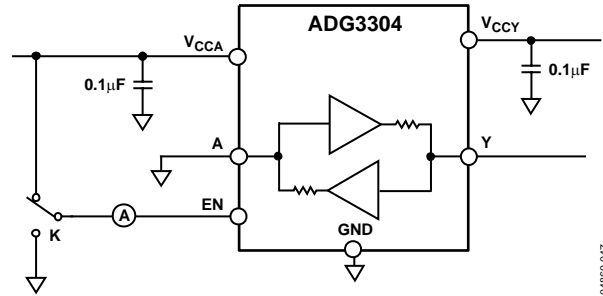

Figure 33. EN Pin Leakage Current

04860-047

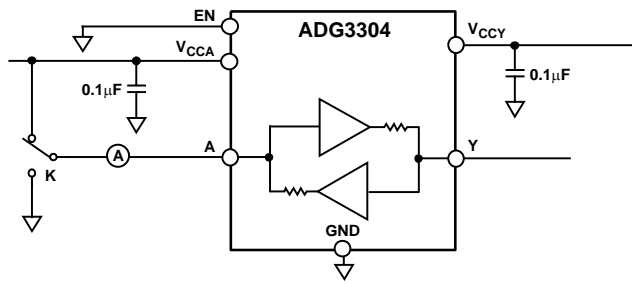

Figure 31. Three-State Leakage Current at Pin A

04860-045

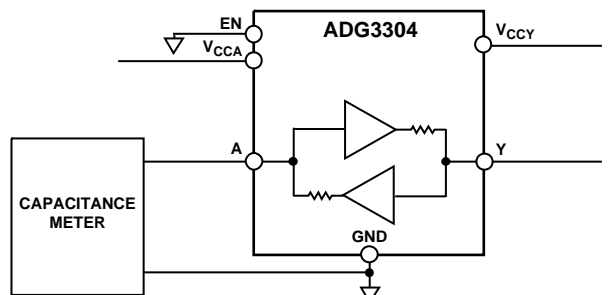

Figure 34. Capacitance at Pin A

04860-048

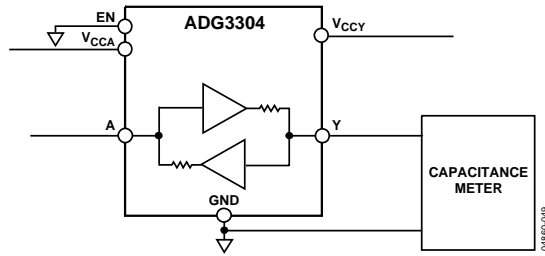
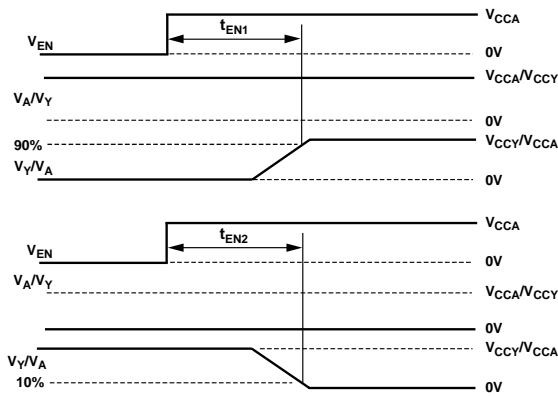
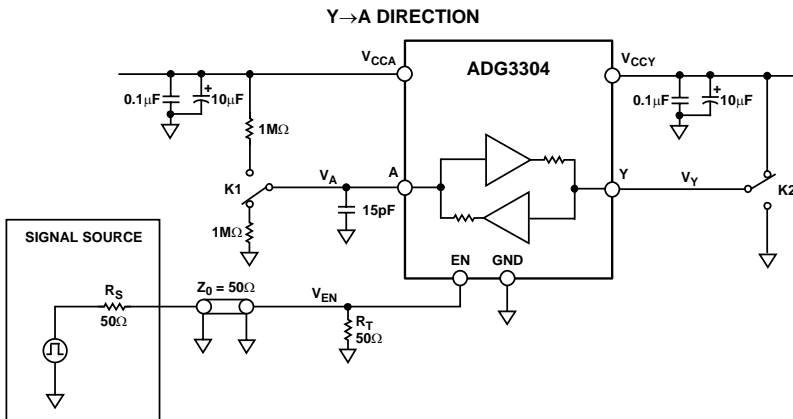
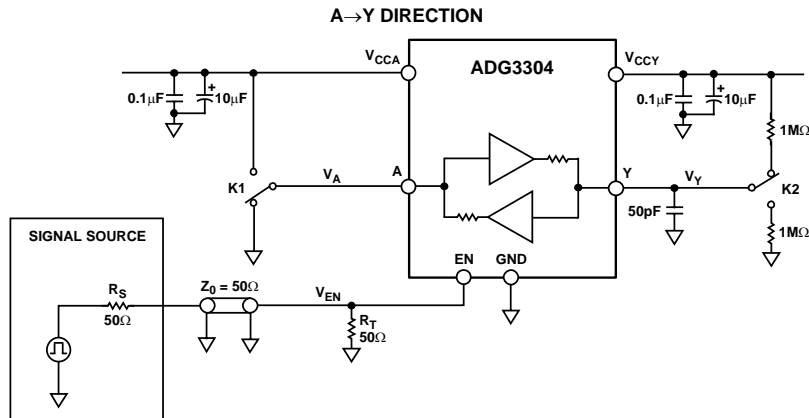

Figure 35. Capacitance at Pin Y



- NOTES**
1.  $t_{EN}$  IS WHICHEVER IS LARGER BETWEEN  $t_{EN1}$  AND  $t_{EN2}$  IN BOTH A→Y AND Y→A DIRECTIONS.

Figure 36. Enable Time

# ADG3304

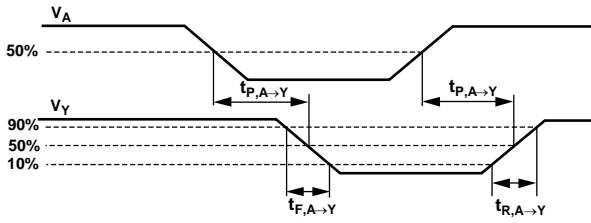
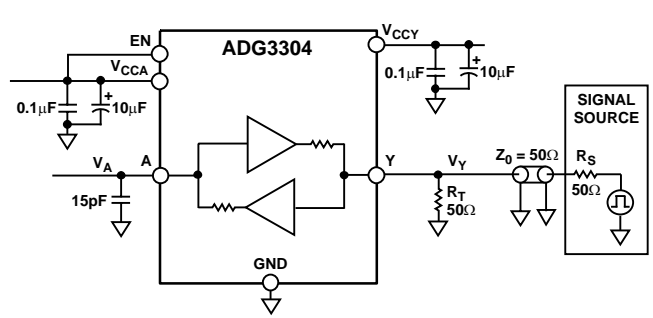
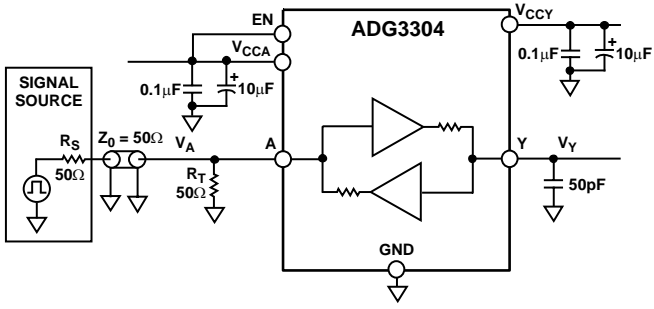

04860-051

Figure 37. Switching Characteristics (A→Y Level Translation)

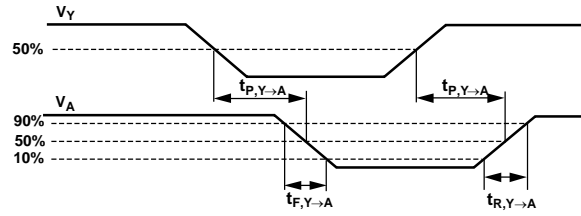

04860-052

Figure 38. Switching Characteristics (Y→A Level Translation)

## TERMINOLOGY

Table 5.

Symbol	Description
$V_{IHA}$	Logic input high voltage at Pins A1 to A4.
$V_{ILA}$	Logic input low voltage at Pins A1 to A4.
$V_{OHA}$	Logic output high voltage at Pins A1 to A4.
$V_{OLA}$	Logic output low voltage at Pins A1 to A4.
$C_A$	Capacitance measured at Pins A1 to A4 (EN = 0).
$I_{LA, HI-Z}$	Leakage current at Pins A1 to A4 when EN = 0 (high impedance state at Pins A1 to A4).
$V_{IHY}$	Logic input high voltage at Pins Y1 to Y4.
$V_{ILY}$	Logic input low voltage at Pins Y1 to Y4.
$V_{OHY}$	Logic output high voltage at Pins Y1 to Y4.
$V_{OLY}$	Logic output low voltage at Pins Y1 to Y4.
$C_Y$	Capacitance measured at Pins Y1 to Y4 (EN = 0).
$I_{LY, HI-Z}$	Leakage current at Pins Y1 to Y4 when EN = 0 (high impedance state at Pins Y1 to Y4).
$V_{IHEN}$	Logic input high voltage at the EN pin.
$V_{ILEN}$	Logic input low voltage at the EN pin.
$C_{EN}$	Capacitance measured at EN pin.
$I_{LEN}$	Enable (EN) pin leakage current.
$t_{EN}$	Three-state enable time for Pins A1 to A4 /Y1 to Y4.
$t_{P, A \rightarrow Y}$	Propagation delay when translating logic levels in the A→Y direction.
$t_{R, A \rightarrow Y}$	Rise time when translating logic levels in the A→Y direction.
$t_{F, A \rightarrow Y}$	Fall time when translating logic levels in the A→Y direction.
$D_{MAX, A \rightarrow Y}$	Guaranteed data rate when translating logic levels in the A→Y direction under the driving and loading conditions specified in Table 1.
$t_{SKEW, A \rightarrow Y}$	Difference between propagation delays on any two channels when translating logic levels in the A→Y direction.
$t_{PPSKEW, A \rightarrow Y}$	Difference in propagation delay between any one channel and the same channel on a different part (under same driving/loading conditions) when translating in the A→Y direction.
$t_{P, Y \rightarrow A}$	Propagation delay when translating logic levels in the Y→A direction.
$t_{R, Y \rightarrow A}$	Rise time when translating logic levels in the Y→A direction.
$t_{F, Y \rightarrow A}$	Fall time when translating logic levels in the Y→A direction.
$D_{MAX, Y \rightarrow A}$	Guaranteed data rate when translating logic levels in the Y→A direction under the driving and loading conditions specified in Table 1.
$t_{SKEW, Y \rightarrow A}$	Difference between propagation delays on any two channels when translating logic levels in the Y→A direction.
$t_{PPSKEW, Y \rightarrow A}$	Difference in propagation delay between any one channel and the same channel on a different part (under the same driving/loading conditions) when translating in the Y→A direction.
$V_{CCA}$	$V_{CCA}$ supply voltage.
$V_{CCY}$	$V_{CCY}$ supply voltage.
$I_{CCA}$	$V_{CCA}$ supply current.
$I_{CCY}$	$V_{CCY}$ supply current.
$I_{HI-Z, A}$	$V_{CCA}$ supply current during three-state mode (EN = 0).
$I_{HI-Z, Y}$	$V_{CCY}$ supply current during three-state mode (EN = 0).

## THEORY OF OPERATION

The ADG3304 level translator allows the level shifting necessary for data transfer in a system where multiple supply voltages are used. The device requires two supplies,  $V_{CCA}$  and  $V_{CCY}$  ( $V_{CCA} \leq V_{CCY}$ ). These supplies set the logic levels on each side of the device. When driving the A pins, the device translates the  $V_{CCA}$ -compatible logic levels to  $V_{CCY}$ -compatible logic levels available at the Y pins. Similarly, since the device is capable of bidirectional translation, when driving the Y pins, the  $V_{CCY}$ -compatible logic levels are translated to  $V_{CCA}$ -compatible logic levels available at the A pins. When  $EN = 0$ , the A1 to A4 and Y1 to Y4 pins are three-stated. When  $EN$  is driven high, the ADG3304 goes into normal operation mode and performs level translation.

### LEVEL TRANSLATOR ARCHITECTURE

The ADG3304 consists of four bidirectional channels. Each channel can translate logic levels in either the  $A \rightarrow Y$  or the  $Y \rightarrow A$  direction. It uses a one-shot accelerator architecture, which ensures excellent switching characteristics. Figure 39 shows a simplified block diagram of a bidirectional channel.

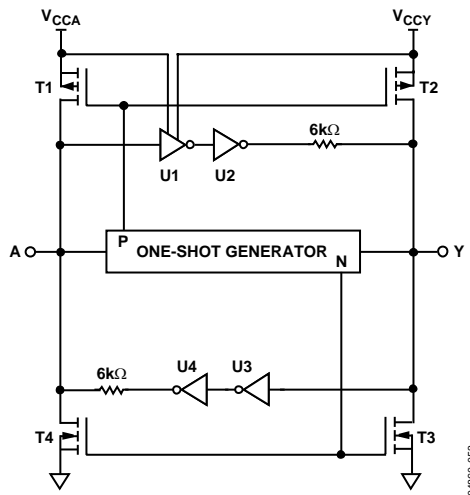

Figure 39. Simplified Block Diagram of an ADG3304 Channel

The logic level translation in the  $A \rightarrow Y$  direction is performed using a level translator (U1) and an inverter (U2), while the translation in the  $Y \rightarrow A$  direction is performed using the inverters U3 and U4. The one-shot generator detects a rising or falling edge present on either the A side or the Y side of the channel. It sends a short pulse that turns on the PMOS transistors (T1 to T2) for a rising edge, or the NMOS transistors (T3 to T4) for a falling edge. This charges/discharges the capacitive load faster, which results in fast rise and fall times.

The inputs of the unused channels (A or Y) should be tied to their corresponding  $V_{CC}$  rail ( $V_{CCA}$  or  $V_{CCY}$ ) or to GND.

### INPUT DRIVING REQUIREMENTS

To ensure correct operation of the ADG3304, the circuit that drives the input of the ADG3304 channels should have an output impedance of less than or equal to  $150 \Omega$  and a minimum peak current driving capability of 36 mA.

### OUTPUT LOAD REQUIREMENTS

The ADG3304 level translator is designed to drive CMOS-compatible loads. If current-driving capability is required, it is recommended to use buffers between the ADG3304 outputs and the load.

### ENABLE OPERATION

The ADG3304 provides three-state operation at the A and Y I/O pins by using the enable (EN) pin, as shown in Table 6.

Table 6. Truth Table

EN	Y I/O Pins	A I/O Pins
0	Hi-Z <sup>1</sup>	Hi-Z <sup>1</sup>
1	Normal operation <sup>2</sup>	Normal operation <sup>2</sup>

<sup>1</sup> High impedance state.

<sup>2</sup> In normal operation, the ADG3304 performs level translation.

While  $EN = 0$ , the ADG3304 enters into three-state mode. In this mode, the current consumption from both the  $V_{CCA}$  and  $V_{CCY}$  supplies is reduced, allowing the user to save power, which is critical, especially on battery-operated systems. The EN input pin can be driven with either  $V_{CCA}$ - or  $V_{CCY}$ -compatible logic levels.

### POWER SUPPLIES

For proper operation of the ADG3304, the voltage applied to the  $V_{CCA}$  must be always less than or equal to the voltage applied to  $V_{CCY}$ . To meet this condition, the recommended power-up sequence is  $V_{CCY}$  first and then  $V_{CCA}$ . The ADG3304 operates properly only after both supply voltages reach their nominal values. It is not recommended to use the part in a system where, during power-up,  $V_{CCA}$  may be greater than  $V_{CCY}$  due to a significant increase in the current taken from the  $V_{CCA}$  supply. For optimum performance, the  $V_{CCA}$  and  $V_{CCY}$  pins should be decoupled to GND as close as possible to the device.



## DATA RATE

The maximum data rate at which the device is guaranteed to operate is a function of the  $V_{CCA}$  and  $V_{CCY}$  supply voltage combination and the load capacitance. It is given by the maximum frequency of a square wave that can be applied to the device, which meets the  $V_{OH}$  and  $V_{OL}$  levels at the output and does not exceed the maximum junction temperature (see the Absolute Maximum Ratings section). Table 7 shows the guaranteed data rates at which the ADG3304 can operate in both directions (A→Y or Y→A level translation) for various  $V_{CCA}$  and  $V_{CCY}$  supply combinations.

**Table 7. Guaranteed Data Rate (Mbps)<sup>1</sup>**

$V_{CCA}$	$V_{CCY}$			
	<b>1.8 V</b> <b>(1.65 V to 1.95 V)</b>	<b>2.5 V</b> <b>(2.3 V to 2.7 V)</b>	<b>3.3 V</b> <b>(3.0 V to 3.6 V)</b>	<b>5 V</b> <b>(4.5 V to 5.5 V)</b>
1.2 V (1.15 V to 1.3 V)	25	30	40	40
1.8 V (1.65 V to 1.95 V)	-	45	50	50
2.5 V (2.3 V to 2.7 V)	-	-	60	50
3.3 V (3.0 V to 3.6 V)	-	-	-	50
5 V (4.5 V to 5.5 V)	-	-	-	-

<sup>1</sup> The load capacitance used is 50 pF when translating in the A→Y direction and 15 pF when translating in the Y→A direction.

## APPLICATIONS

The ADG3304 is designed for digital circuits that operate at different supply voltages; therefore, logic level translation is required. The lower voltage logic signals are connected to the A pins, and the higher voltage logic signals are connected to the Y pins. The ADG3304 can provide level translation in both directions from A→Y or Y→A on all four channels, eliminating the need for a level translator IC for each direction. The internal architecture allows the ADG3304 to perform bidirectional level translation without an additional signal to set the direction in which the translation is made. It also allows simultaneous data flow in both directions on the same part, for example, when two channels translate in A→Y direction while the other two translate in Y→A direction. This simplifies the design by eliminating the timing requirements for the direction signal and reduces the number of ICs used for level translation.

Figure 40 shows an application where two microprocessors operating at 1.8 V and 3.3 V, respectively, can transfer data simultaneously using two full-duplex serial links, TX1/RX1 and TX2/RX2.

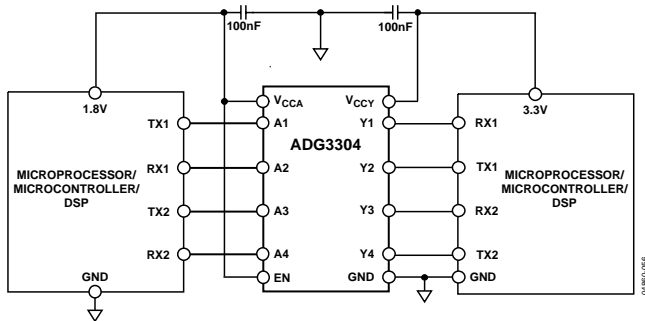

Figure 40. 1.8 V to 3.3 V Level Translation Circuit on Two Full-Duplex Serial Links

When the application requires level translation between a microprocessor and multiple peripheral devices, the ADG3304 I/O pins can be three-stated by setting EN = 0. This feature allows the ADG3304 to share the data buses with other devices without causing contention issues. Figure 41 shows an application where a 1.8 V microprocessor is connected to 3.3 V peripheral devices using the three-state feature.

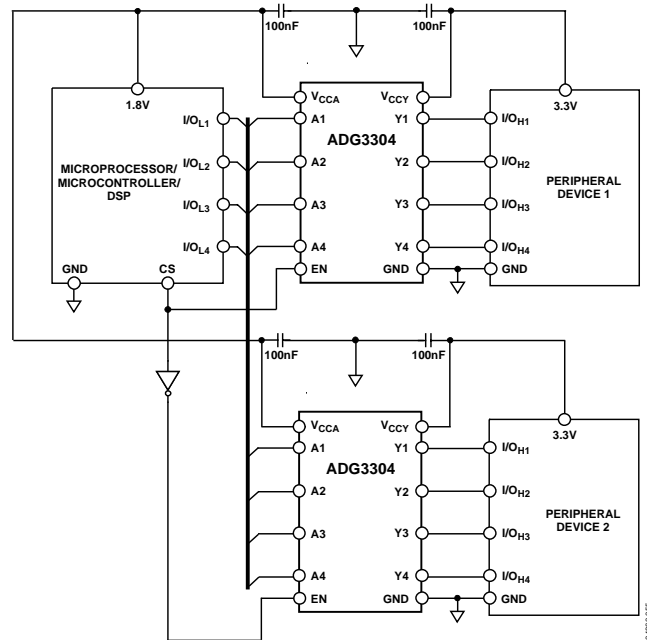

Figure 41. 1.8 V to 3.3 V Level Translation Circuit Using the Three-State Feature

## LAYOUT GUIDELINES

As with any high speed digital IC, the printed circuit board layout is important for the overall performance of the circuit. Care should be taken to ensure proper power supply bypass and return paths for the high speed signals. Each  $V_{CC}$  pin ( $V_{CCA}$  and  $V_{CCY}$ ) should be bypassed using low effective series resistance (ESR) and effective series inductance (ESI) capacitors placed as close as possible to the  $V_{CCA}$  and  $V_{CCY}$  pins. The parasitic inductance of the high speed signal track might cause significant overshoot. This effect can be reduced by keeping the length of the tracks as short as possible. A solid copper plane for the return path (GND) is also recommended.

## OUTLINE DIMENSIONS

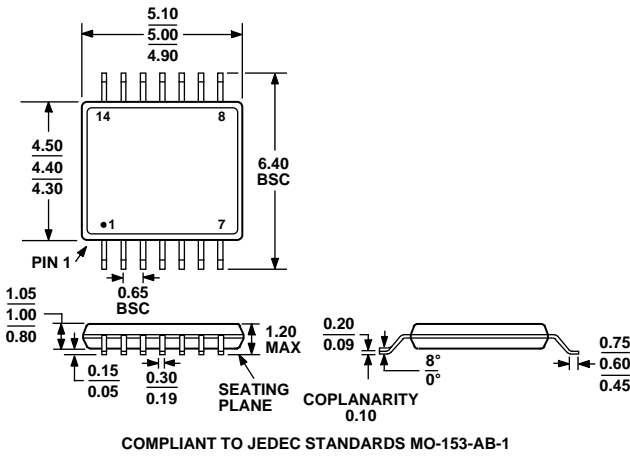

Figure 42. 14-Lead Thin Shrink Small Outline Package [TSSOP] (RU-14)  
Dimensions shown in millimeters

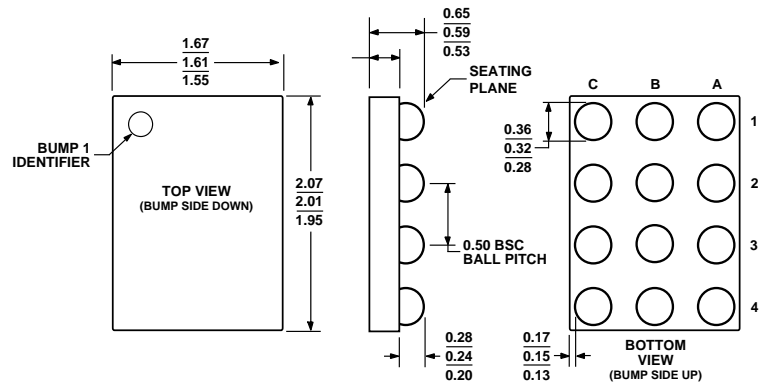

Figure 43. 12-Bump Wafer Level Chip Scale Package [WLCSP] (CB-12)  
Dimensions shown in millimeters

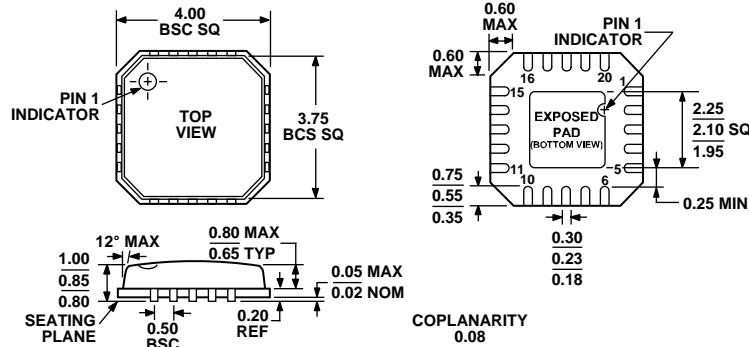

Figure 44. 20-Lead Lead Frame Chip Scale Package [LFCSP\_VQ] 4 x 4 mm Body, Very Thin Quad (CP-20-1)  
Dimensions shown in millimeters

## ORDERING GUIDE

Model	Temperature Range	Package Description	Branding <sup>1</sup>	Package Option
ADG3304BRUZ <sup>2</sup>	-40°C to +85°C	14-Lead Thin Shrink Small Outline Package [TSSOP]		RU-14
ADG3304BRUZ-REEL <sup>2</sup>	-40°C to +85°C	14-Lead Thin Shrink Small Outline Package [TSSOP]		RU-14
ADG3304BRUZ-REEL <sup>2,7</sup>	-40°C to +85°C	14-Lead Thin Shrink Small Outline Package [TSSOP]		RU-14
ADG3304BCPZ-REEL <sup>2</sup>	-40°C to +85°C	20-Lead Lead Frame Chip Scale Package [LFCSP_VQ]		CP-20-1
ADG3304BCPZ-REEL <sup>2,7</sup>	-40°C to +85°C	20-Lead Lead Frame Chip Scale Package [LFCSP_VQ]		CP-20-1
ADG3304BCBZ-REEL <sup>2,3</sup>	-40°C to +85°C	12-Bump Wafer Level Chip Scale Package [WLCSP]	SDC	CB-12
ADG3304BCBZ-REEL <sup>2,3,7</sup>	-40°C to +85°C	12-Bump Wafer Level Chip Scale Package [WLCSP]	SDC	CB-12

<sup>1</sup> Branding on these packages is limited to three characters due to space constraints.

<sup>2</sup> Z = Pb-free part.

<sup>3</sup> Contact your sales representative for availability. Product under development.

**ADG3304**

**NOTES**